

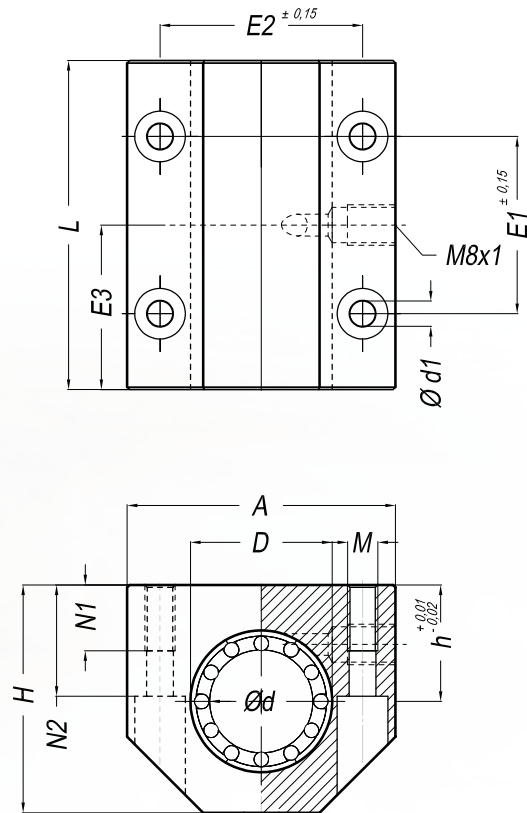

KTGC29 – KUGELHÜLSEEINHEIT

„COMPACT“ – TANDEM, LINEARKUGELHÜLSE / LINEARGLEITLAGER

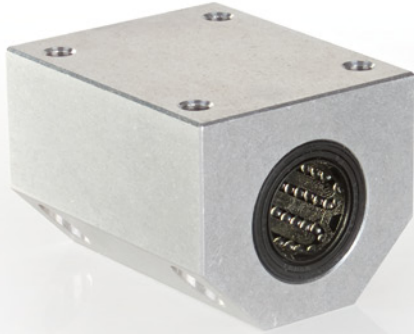

Passende Kugelhülsen finden Sie auf Seite 402.

Artikelnr.	Ød	ØD	A	H	h	L	E1	E2	E3	Ød1	N1	N2	M	kg
B-KTGC29-12	12	19	40	33	17	60	35	29	30	4,3	11	16	M5	0,15
B-KTGC29-16	16	24	45	38	19	65	40	34	32,5	4,3	11	18	M5	0,17
B-KTGC29-20	20	28	53	45	23	65	45	40	32,5	5,3	13	22	M6	0,25
B-KTGC29-25	25	35	62	54	27	85	55	48	42,5	6,6	18	26	M8	0,46
B-KTGC29-30	30	40	67	60	30	105	70	53	52,5	6,6	18	29	M8	0,68
B-KTGC29-40	40	52	87	76	39	125	85	69	62,5	8,4	22	38	M10	1,3
B-KTGC29-50	50	62	103	92	47	145	100	82	72,5	10,5	26	46	M12	2,1

- Befestigungsschrauben DIN EN ISO 4762 – 8.8, Federring
- Gewichtsangabe ohne Kugelhülse
- Schmierbohrung M8 x 1