

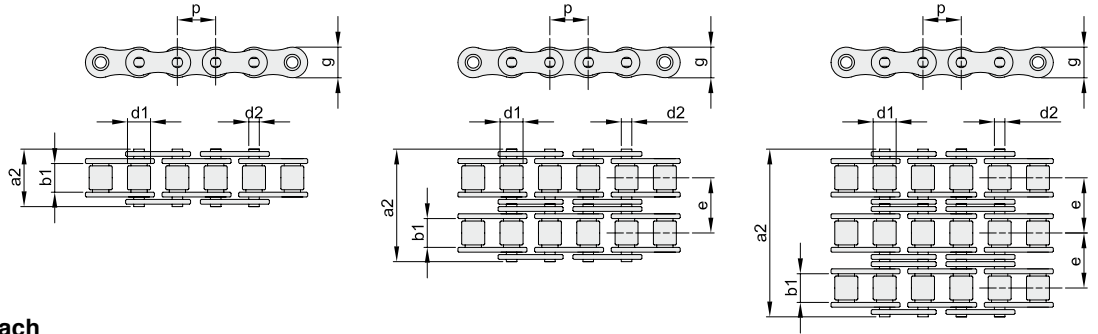

ROLLENKETTEN DIN 8188 – AMERIKANISCHER STANDARD „ASA“

Temperaturbereich
von -10°C bis +150°C



Die Ketten sind produziert nach
DIN ISO 9001 – ISO 14001
und API 7F zertifizierter Firma

Ketten vorgereckt
3 Meter VPE



EINFACH

ANSI	Artikelnr.	p		b ₁ mm min.	d ₂ mm	d ₁ mm max.	a ₂ mm max.	g mm max.	Bruchkraft		q kg/m ≈
		mm	inch						Minimum KN	Durchschnitt KN	
35-1	620035000	9,525	3/8"	4,77	3,58	5,08	13,2	9,05	7,8	10,1	0,34
40-1	620040000	12,7	1/2"	7,95	3,96	7,92	17,8	12,07	14,1	18,8	0,63
50-1	620050000	15,875	5/8"	9,53	5,08	10,16	21,8	15,09	22,2	30,4	1,04
60-1	620060000	19,05	3/4"	12,70	5,94	11,91	26,9	18,08	31,8	41,7	1,52
80-1	620080000	25,4	1"	15,88	7,92	15,88	33,5	24,13	56,7	72,6	2,58
100-1	620100000	31,75	1 1/4"	19,05	9,53	19,05	41,1	30,18	88,5	110,4	3,85
120-1	620120000	38,1	1 1/2"	25,40	11,10	22,23	50,8	36,20	127,0	144,6	5,61
140-1	620140000	44,45	1 3/4"	25,40	12,70	25,40	54,9	42,24	172,4	190,8	7,24
160-1	620160000	50,8	2"	31,75	14,27	28,58	65,5	48,26	226,8	253,4	9,91
60-1H	621060000	19,05	3/4"	12,70	5,94	11,91	31,2	18,08	31,2	42,1	1,81
80-1H	621080000	25,4	1"	15,88	7,92	15,88	38,0	24,13	55,6	72,6	3,00
100-1H	621100000	31,75	1 1/4"	19,05	9,53	19,05	45,4	30,18	86,8	110,4	4,38

ZWEIFACH

ANSI	Artikelnr.	p		b ₁ mm min.	d ₂ mm	d ₁ mm max.	a ₂ mm max.	g mm max.	e mm	Bruchkraft		q kg/m ≈
		mm	inch							Minimum KN	Durchschnitt KN	
35-2	620035200	9,525	3/8"	4,77	3,58	5,08	21,6	9,05	10,13	15,6	20,3	0,67
40-2	620040200	12,7	1/2"	7,95	3,96	7,92	32,3	12,07	14,38	28,2	37,7	1,26
50-2	620050200	15,875	5/8"	9,53	5,08	10,16	39,9	15,09	18,11	44,4	60,8	2,05
60-2	620060200	19,05	3/4"	12,70	5,94	11,91	49,8	18,08	22,78	63,3	83,4	3,01
80-2	620080200	25,4	1"	15,88	7,92	15,88	62,7	24,13	29,29	113,4	145,1	5,13
100-2	620100200	31,75	1 1/4"	19,05	9,53	19,05	77,0	30,18	35,76	177,0	220,8	7,64
120-2	620120200	38,1	1 1/2"	25,40	11,10	22,23	96,3	36,20	45,44	254,0	289,3	11,13
140-2	620140200	44,45	1 3/4"	25,40	12,70	25,40	103,6	42,24	48,87	344,8	381,6	14,37
160-2	620160200	50,8	2"	31,75	14,27	28,58	124,2	48,26	58,55	453,6	506,7	19,68

DREIFACH

ANSI	Artikelnr.	p		b ₁ mm min.	d ₂ mm	d ₁ mm max.	a ₂ mm max.	g mm max.	e mm	Bruchkraft		q kg/m ≈
		mm	inch							Minimum KN	Durchschnitt KN	
*35-3	620035300	9,525	3/8"	4,77	3,58	5,08	31,8	9,05	10,13	23,4	30,5	0,99
*40-3	620040300	12,7	1/2"	7,95	3,96	7,92	46,7	12,07	14,38	42,3	56,6	1,98
*50-3	620050300	15,875	5/8"	9,53	5,08	10,16	57,9	15,09	18,11	66,6	82,5	3,06
*60-3	620060300	19,05	3/4"	12,70	5,94	11,91	72,6	18,08	22,78	95,4	120,1	4,50
*80-3	620080300	25,4	1"	15,88	7,92	15,88	91,7	24,13	29,29	170,1	201,9	7,67
*100-3	620100300	31,75	1 1/4"	19,05	9,53	19,05	113,0	30,18	35,76	265,5	313,9	11,43
*120-3	620120300	38,1	1 1/2"	25,40	11,10	22,23	141,7	36,20	45,44	381,0	433,9	16,67
*140-3	620140300	44,45	1 3/4"	25,40	12,70	25,40	152,4	42,24	48,87	517,2	583,4	21,51
*160-3	620160300	50,8	2"	31,75	14,27	28,58	182,9	48,26	58,55	680,4	760,1	29,45

* Auf Anfrage