

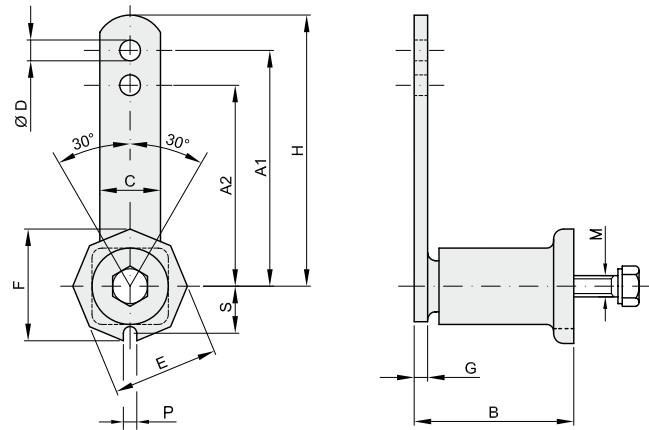

UNIVERSAL KETTENSPELLER TYP „TE“



Beschreibung	Artikelnr.	A1	A2	B	C	Ø D	E	F	G	H	Drehmoment max. in N Δ 0-32°		M	P	S	kg
											A1	A2				
TE 2	6021000020	80	60	52	20	8,5	35	38	5	90	0 - 90	0 - 110	M 6	8	16,5	0,25
TE 3	6021000030	100	80	63	25	10,5	46	48	5	115	0 - 140	0 - 170	M 8	8,5	19,5	0,45
TE 4	6021000040	100	80	78	30	10,5	56	60	6	115	0 - 320	0 - 430	M10	8,5	24,5	0,68
TE 5	6021000050	130	100	108	50	12,5	72	78	8	155	0 - 820	0 - 1050	M12	10,5	34	1,70
TE 6	6021000060	175	140	145	60	20,5	93	100	10	205	0 - 1500	0 - 1880	M16	12,5	42	3,70
TE 7	6021000070	220	175	198	70	20,5	106	114	12	255	0 - 2500	0 - 3200	M20	12,5	50	6,50

Beschreibung	Artikelnr.	A1	A2	B	C	Ø D	E	F	G	H	Drehmoment max. in N Δ 0-32°		M	P	S	kg
											A1	A2				
TE 2	6021000120	80	60	52	20	8,5	35	38	5	90	0 - 90	0 - 110	M 6	8	16,5	0,25
TE 3	6021000130	100	80	63	25	10,5	46	48	5	115	0 - 140	0 - 170	M 8	8,5	19,5	0,45
TE 4	6021000140	100	80	78	30	10,5	56	60	6	115	0 - 320	0 - 430	M10	8,5	24,5	0,68
TE 5	6021000150	130	100	108	50	12,5	72	78	8	155	0 - 820	0 - 1050	M12	10,5	34	1,70



KETTENGLEITER TYP „CRS“

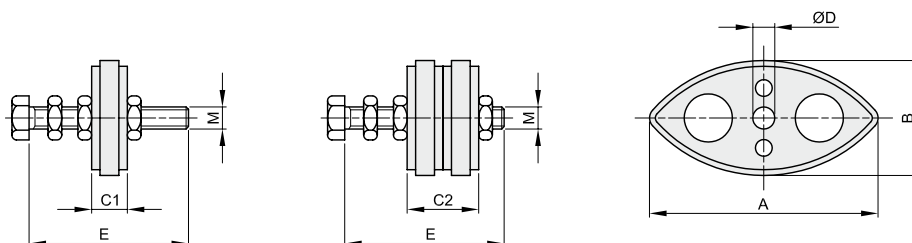

Beschreibung	Ketten	Artikelnr.	ISO	A	B	C1	C2	Ø D	M	E	einfach kg	zweifach kg
CRS 3/8"	3/8" x 7/32"	6023330000	06B	74	40	10,2	20,4	8	M8	45	0,05	0,07
CRS 1/2"	1/2" x 5/16"	6023340000	08B	96	50	13,9	27,8	10	M10	60	0,11	0,15
CRS 5/8"	5/8" x 3/8"	6023350000	10B	125	55	16,5	33,0	10	M10	60	0,14	0,22
CRS 3/4"	3/4" x 7/16"	6023360000	12B	147	80	19,5	39,0	12	M12	80	0,22	0,36