



# ZAHNRIEMENRÄDER FÜR TAPERBUCHSEN – ISO 5294

## L 075

Teilung 3/8" (9,525 mm)

für Zahnriemenbreite 3/4" (19,05 mm)

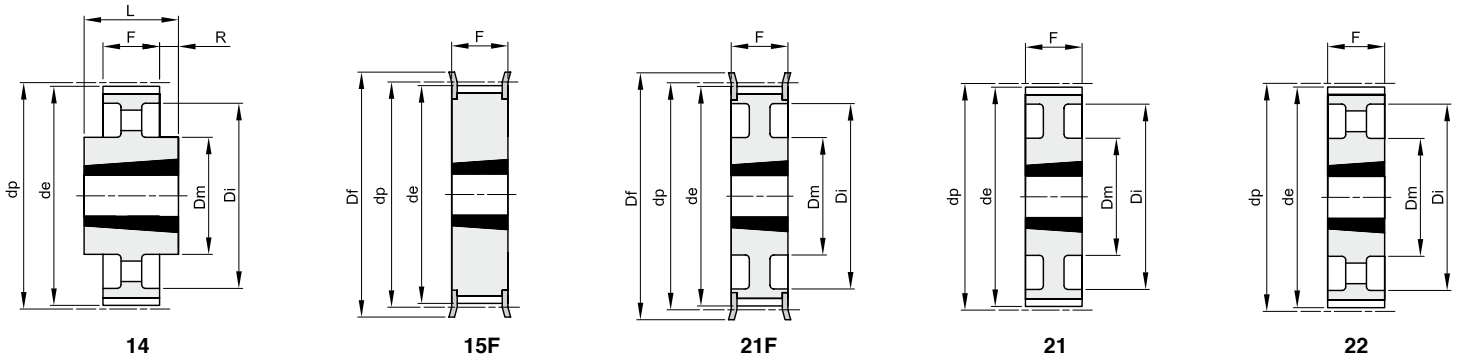

Werkstoff: Stahl  
Werkstoff: Grauguss (GG)

code	Typ	Werkstoff	Zähne- zahl	Spann- buchsentyp	Bohrung max	dp	de	Df	Dm	Di	F	L	R	Nr. Bordscheiben	kg
TL 18 L 075	15F	St	18	1108	28	54,57	53,81	60			25,0	25,0		308	0,25
TL 19 L 075	15F	St	19	1108	28	57,61	56,84	63			25,0	25,0		309	0,32
TL 20 L 075	15F	St	20	1108	28	60,64	59,88	66			25,0	25,0		310	0,35
TL 21 L 075	15F	St	21	1108	28	63,67	62,91	71			25,0	25,0		311	0,40
TL 22 L 075	15F	St	22	1108	28	66,70	65,94	75			25,0	25,0		312	0,44
TL 23 L 075	15F	St	23	1108	28	69,73	68,97	79			25,0	25,0		313	0,48
TL 24 L 075	15F	St	24	1108	28	72,77	72,00	79			25,0	25,0		313	0,55
TL 25 L 075	15F	St	25	1108	28	75,80	75,04	83			25,0	25,0		314	0,63
TL 26 L 075	15F	St	26	1108	28	78,83	78,07	87			25,0	25,0		315	0,66
TL 27 L 075	15F	St	27	1108	28	81,86	81,10	87			25,0	25,0		315	0,70
TL 28 L 075	15F	St	28	1108	28	84,89	84,13	91			25,0	25,0		316	0,72
TL 30 L 075	15F	St	30	1108	28	90,96	90,20	97			25,0	25,0		318	0,93
TL 32 L 075	15F	St	32	1108	28	97,02	96,26	103			25,0	25,0		320	1,10
TL 36 L 075	15F	St	36	1610	42	109,15	108,39	115			25,0	25,0		323	1,20
TL 40 L 075	15F	St	40	1610	42	121,28	120,51	127			25,0	25,0		327	1,70
TL 48 L 075	21F	St	48	1610	42	145,53	144,77	152	92	120	25,0	25,0		334	2,60
TL 60 L 075	21	St	60	1610	42	181,91	181,15		92	166	25,0	25,0			3,00
TL 72 L 075	22	GG	72	1610	42	218,30	217,53		92	202	25,0	25,0			2,33
TL 84 L 075	14	GG	84	2012	50	254,68	253,90		106	236	25,0	32,0	3,5		3,55
TL 96 L 075	14	GG	96	2012	50	291,06	290,30		106	270	25,0	32,0	3,5		3,95
TL120 L 075	14	GG	120	2012	50	363,83	363,07		106	343	25,0	32,0	3,5		5,61